

GLOBAL CLEAN ENERGY

Brad Sorensen, Inventor, Founder

California Office, 515 13th Street, Manhattan Beach, CA 90266, 310-802-8082, sorensen.design@gte.net

To: The Foundation Funder

Business Plan

Global Clean Energy Business Plan

The following document contains confidential information.

Fill out, sign and fax this agreement to 310-802-8082 and mail to 515 13th Street, Manhattan Beach, CA 90266 before reviewing the content of the document.

CONFIDENTIALITY & NON-CIRCUMVENTION AGREEMENT

This Confidentiality & Non-Circumvention Agreement ("Agreement") is entered into on Today's date _____ ("Date")

Regarding the: Global Clean Energy Electric Generator Invention

Between Brad Sorensen, Invention and Design, ("Company" and "Owner") and

_____, ("Recipient").

DEFINITIONS. For the purposes of this Agreement, "Confidential Information" shall mean that Recipient shall not disclose any information concerning the inventions of the Owner to any individual or entity at any time. Confidential Information shall mean that Recipient shall not disclose any information, written, drawn or spoken, including, but not limited to, sketches, plans, layouts, drawings, renderings, paintings, computer aided design, business contacts, floor-plans, funding sources, business contacts, business plans, technology, operations, systems, inventions, trademarks, copyrights, trade secrets, concepts, prototypes or business affairs of Owner, or of another party whose information Owner has in its contracts, to any individual or entity at any time which (i) is disclosed by Owner or its affiliates to Recipient or its affiliates, indicating its confidential or proprietary nature, or is obviously confidential or proprietary by its nature, or (ii) is developed during the relationship between the parties and would give or increase the advantage of Owner's competitors over the Owner or diminish the Owner's advantage over its competitors. The term "affiliate" shall mean any person or entity controlling, controlled by or under common control with a party. Recipient agrees to follow all of Owner's security procedures including, but not limited to, maintaining the secrecy of all Confidential Information and all of Owner's information and materials (whether confidential or not). Recipient further agrees that all Confidential Information and materials of which Recipient becomes aware shall be maintained by Recipient in a manner that will preserve its confidentiality and secrecy.

EXCLUSIONS. Confidential Information shall not include any information of Owner that (i) is already known to Recipient at time of its disclosure; (ii) becomes available to Recipient from a lawful source other than the Owner; (iii) is or becomes public knowledge without the fault of the Recipient; (iv) is or becomes on an unrestricted basis to a third party from Owner or from someone acting under Owner's control; (v) is communicated by Recipient to a third party with express written consent of the Owner; (vi) is lawfully required to be disclosed, provided that before making such disclosure, the Recipient shall immediately give Owner written notice and cooperate in Owner's actions to secure confidential handling of such information.

OWNERSHIP. All Confidential Information, in whatever form, including without limitation, drawings, sketches, renderings, computer aided design, contracts, business contacts and/or information in computer software or held in electronic storage media, shall be and remain the property of the Owner. All such Confidential Information shall be returned to Owner promptly upon written request and shall not be retained in any form by Recipient.

TERM. For a period of two (2) years from the date of disclosure, Recipient shall not disclose any Confidential Information to any person or entity except employees of Recipient and its affiliates who have a need to know and who have executed this Agreement and have been informed of Recipient's obligations under this Agreement. Recipient shall use not less than the same degree of care to avoid disclosure of Confidential Information as Recipient used for its own confidential information of like importance and, at a minimum, shall exercise reasonable care. Either party may terminate this Agreement by written notice to the other. However, all rights and obligations under this Agreement shall survive with respect to Confidential Information disclosed prior to termination.

NON-CIRCUMVENTION. The parties agree that confidential Information shall not be used for the enrichment, directly or indirectly, of the Recipient or its affiliates, without the express written consent of Owner. The parties further agree that following receipt of Confidential Information from Owner, Recipient shall not contract or attempt to sell to, transact with or purchase from Owner-provided sources without the written permission from Owner.

REMEDIES. The parties agree that in the event of a breach or threatened breach of the terms of this Agreement, the non-breaching party shall be entitled to an injunction in addition to, and not in lieu of, any other legal or equitable relief including monetary damages. The parties acknowledge that Confidential Information is valuable and unique and that its disclosure or circumvention will result in irreparable damage to Owner. Recipient understands and agrees that any disclosure or misappropriation of any of the Confidential Information at any time in violation of this Agreement will cause Owner irreparable harm, including, but not limited to; adversely affecting the ability of the Owner to file trademarks, patents or copyrights on the confidential information, allowing competitors to develop similar products to the Owner, allowing competitors to gain a market advantage over the Owner and/or placing Owner in breach of their respective agreements with third parties, and given that the extent or amount of such damages would be difficult or impossible to ascertain in a court of law, Recipient agrees that Recipient shall pay to Owner an amount equal to five million dollars of liquidated damages, and not as a penalty, which amount represents the result of a reasonable endeavor by Owner and Recipient to ascertain the fair average compensation for any harm that Owner will sustain as the result of such disclosure or misappropriation. Recipient expressly agrees that this liquidated damages amount represents reasonable compensation for the harm that will be incurred by Owner as a result of such disclosure or misappropriation, that this liquidated damages provision is necessary because Owner will in fact suffer significant damages as a result of violation of this Agreement, and that the amount of those damages is impracticable to calculate or ascertain with certainty or specificity. Notwithstanding the liquidated damages provided for herein, Recipient understands and agrees that such liquidated damages or any monetary damages will not be sufficient to avoid and/or compensate Owner for the unauthorized use or disclosure of the Confidential Information and that injunctive or other equitable relief would be appropriate to prevent any improper actual or threatened use or disclosure of the Confidential Information or other breach of this Agreement.

MISCELLANEOUS. Any failure or delay by the parties in exercising any right, power or privilege hereunder shall not invalidate the rights, power or privileges provided under this Agreement. This Agreement shall be governed by the laws of the State of California, without regard to the principles regarding choice of law. If any provision of this Agreement shall be invalid under such laws, the validity of the others shall not be affected. The State and/or Federal courts located in Los Angeles County, California shall be the exclusive and proper jurisdiction for any disputes arising hereunder. Should a party be found to be in violation of this Agreement following due process, the violating party agrees to pay all costs and expenses, including attorney's fees and disbursements incurred by the non-violating (other party) in enforcing the terms of this Agreement. Recipient agrees that the court's ruling shall be final and binding and not subject to appeal or challenge. Recipient further agrees that the court proceedings, testimony, discovery and documents filed in the course of such proceedings, including the fact that the court case is being conducted, will be treated as confidential and will not be disclosed to any third party to such proceedings, except to the court and the court staff, the parties' attorneys and their staff, and any experts retained by the parties.

COMPLETE AGREEMENT. This Agreement: (i) is the complete agreement of the parties concerning this subject matter; (ii) may not be amended except in writing signed by both parties; and (iii) is executed by authorized representative of each party. Recipient hereby acknowledges and certifies that Recipient has read and understands this Agreement that the consequences and implications of its breach have been explained to Recipient, and that Recipient agrees to abide by the terms of this Agreement. Recipient agrees, if required or asked by Owner, to execute in the future an additional confidentiality agreement in connection with Recipient should Owner decide such an agreement is necessary for any reason. The parties agree that facsimile signatures are binding and considered as original.

IN WITNESS WHEREOF, the undersigned, intending to be legally bound, have executed this Agreement effective as of the date indicated above.

Name of Recipient Company and/or Individual Recipient

Signature

Name & Title

Date

Email address

Global Clean Energy Business Plan

Brad Sorensen

515 13th Street, Manhattan Beach, CA 90266 310-802-8082 sorensen.design@gte.net

TABLE OF CONTENTS

1. INTRODUCTION
2. WINDPOWER HISTORY
3. OVERALL CONCEPT
4. COMPARISON
5. VARIETY OF WIND SPEED
6. PERMANANCE
7. ELECTRICAL ENERGY GENERATION
8. WIND POWER APPROPRIATE ALTERNATOR/GENERATOR
9. BUSINES DESCRIPTION
10. MANAGEMENT
11. PERSONNEL
12. TECHNOLOGY/PROPRIETARY RIGHTS
13. PROTOTYPE TESTING
14. MARKETS
15. DISTRIBUTION CHANNELS
16. COMPETITION
17. INDEPENDENT ENGINEERING REVIEW
18. RETURN ON INVESTMENT
19. FRANCHISE RETURN ON INVESTMENT
20. NATIVE AMERICAN COOPERATIVE RETURN ON INVESTMENT
21. USE OF FUNDS CHART
22. SUMMARY
23. GOAL
24. CONTACT
25. ENERGY PRODUCED AT EACH WIND SPEED CHART
26. PROPELLER COMPARISON CHART
27. COAL COST COMPARISON CHART
28. PRODUCT COMPARISON CHART
29. SAMPLE BUSINESS STRUCTURES
30. CORPORATE RESOLUTION

Global Clean Energy Business Plan

Brad Sorensen

515 13th Street, Manhattan Beach, CA 90266 310-802-8082 Sorensen.design@gte.net

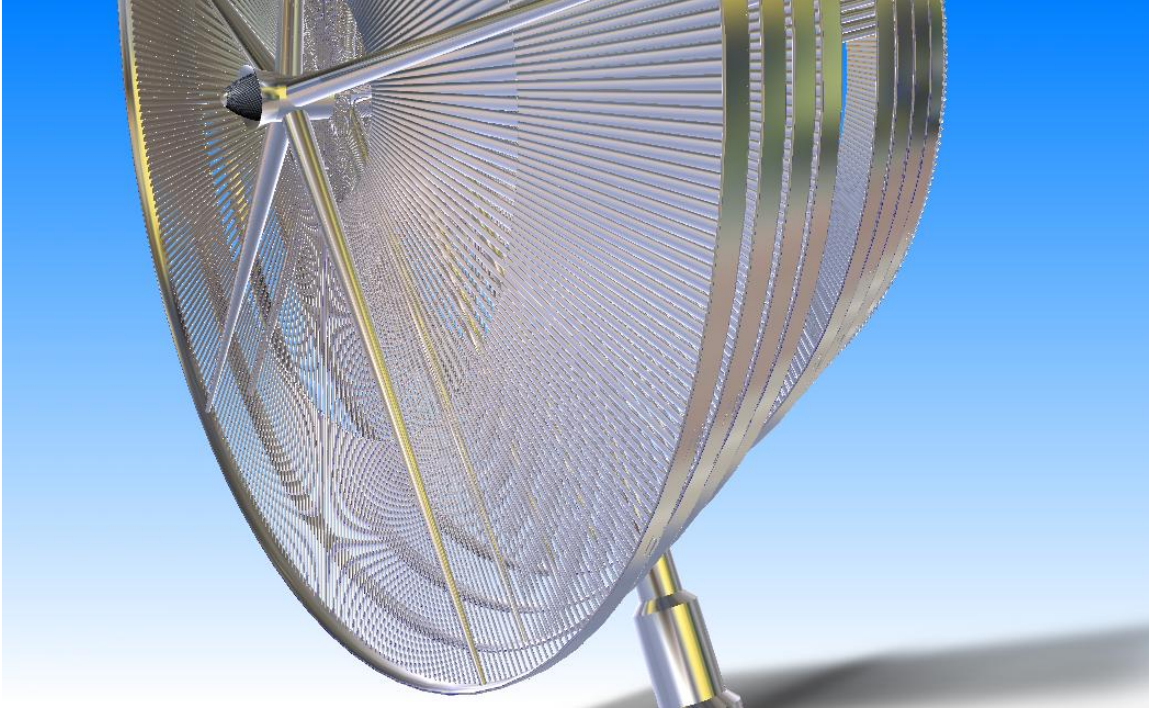

How to satisfy the world's need for electricity without pollution?

1. INTRODUCTION

United States President George W. Bush has called for innovation in wind power in every one of his State of the Union addresses. Nobel Prize winner and past United States Vice President Gore defined the global warming issue with great clarity in his movie, "An Inconvenient Truth." The Global Clean Energy Device was created as one way of slowing global warming by displacing carbon emission sources while making profits of millions or billions of dollars worldwide to make this clean energy source sustainable economically.

Wind is created by the uneven heating of the Earth's surface as it spins in front of the sun. The uneven heating produces high and low atmospheric pressures which causes wind. As long as the Earth spins in front of the sun, we will have wind. Wind is perpetual. The Global Clean Energy Device taps into that perpetual energy source in a very efficient manner. Perpetual energy results.

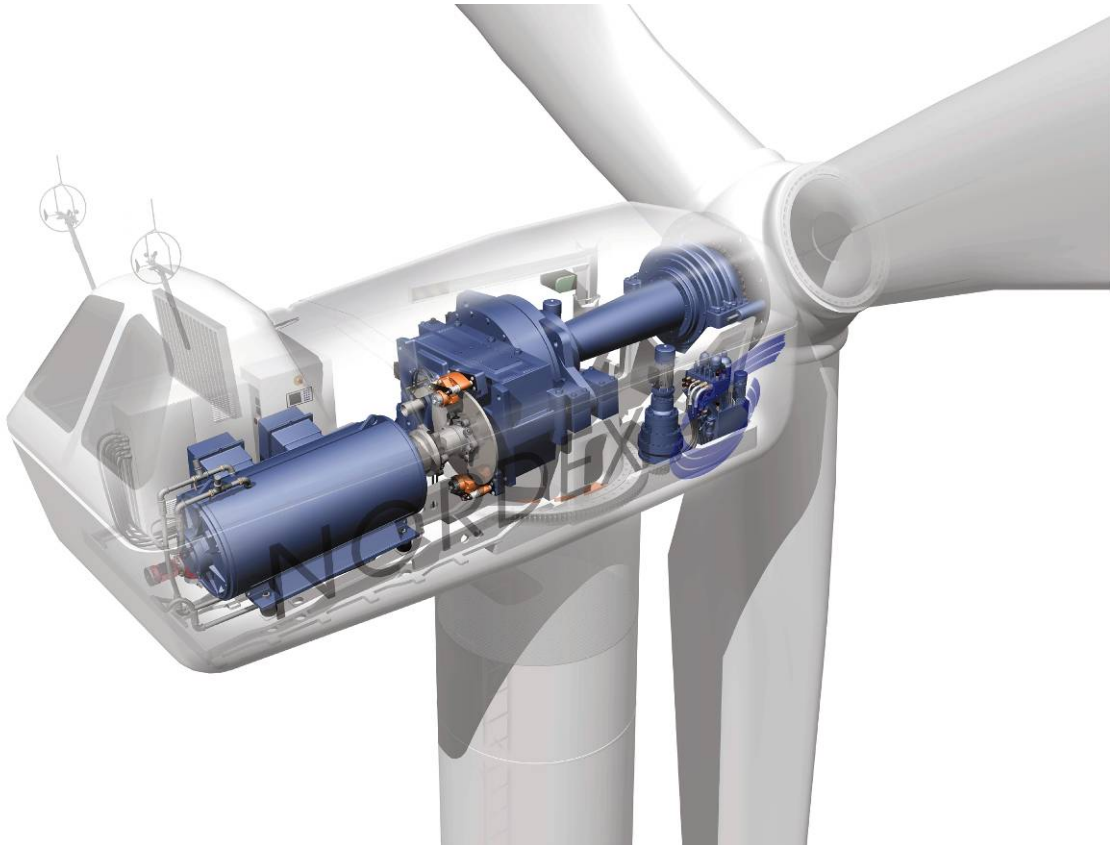

Today, the common way of tapping into wind energy is the use of the standard 3 bladed propeller.

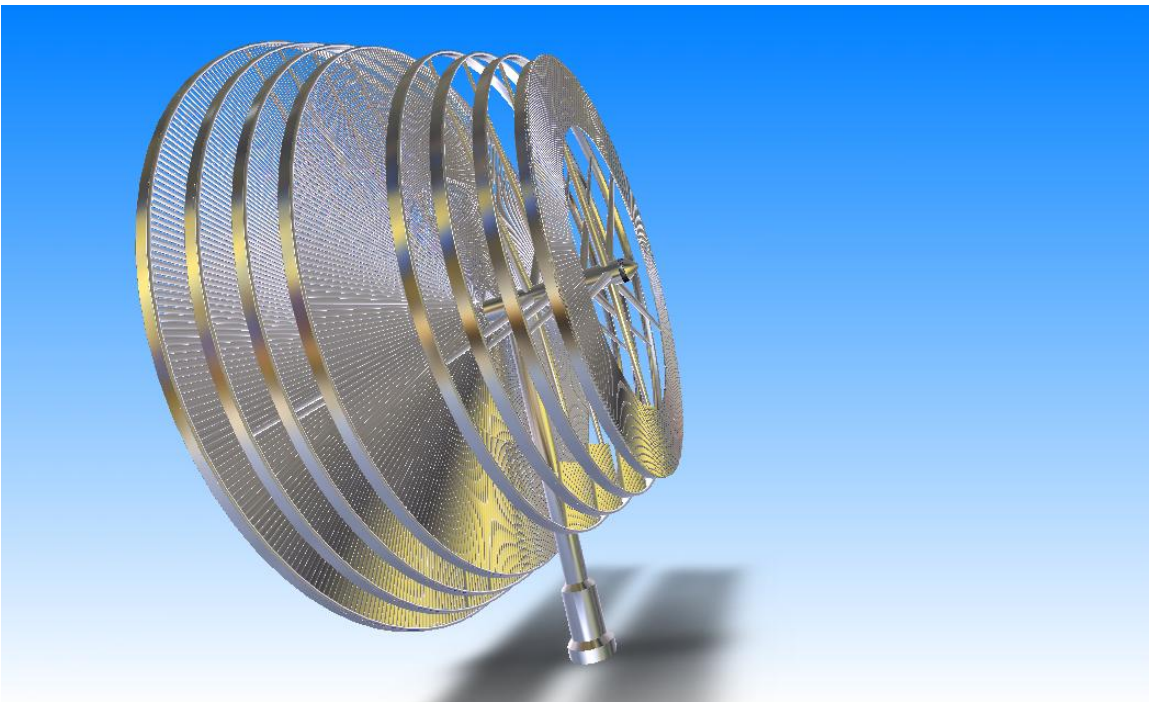

The Global Clean Energy Device is a jet turbine for gathering a higher amount of wind energy.

2. WINDPOWER HISTORY

Several companies make 3 bladed propeller windmills such as GE (General Electric) Vestas, Siemens, Mitsubishi, Nordex and many others. For comparison we will use GE to refer to these common propeller windmills.

Windmills like the GE models are already doing great work by providing clean energy to displace carbon emissions and slow global warming. Some GE models are also currently very profitable.

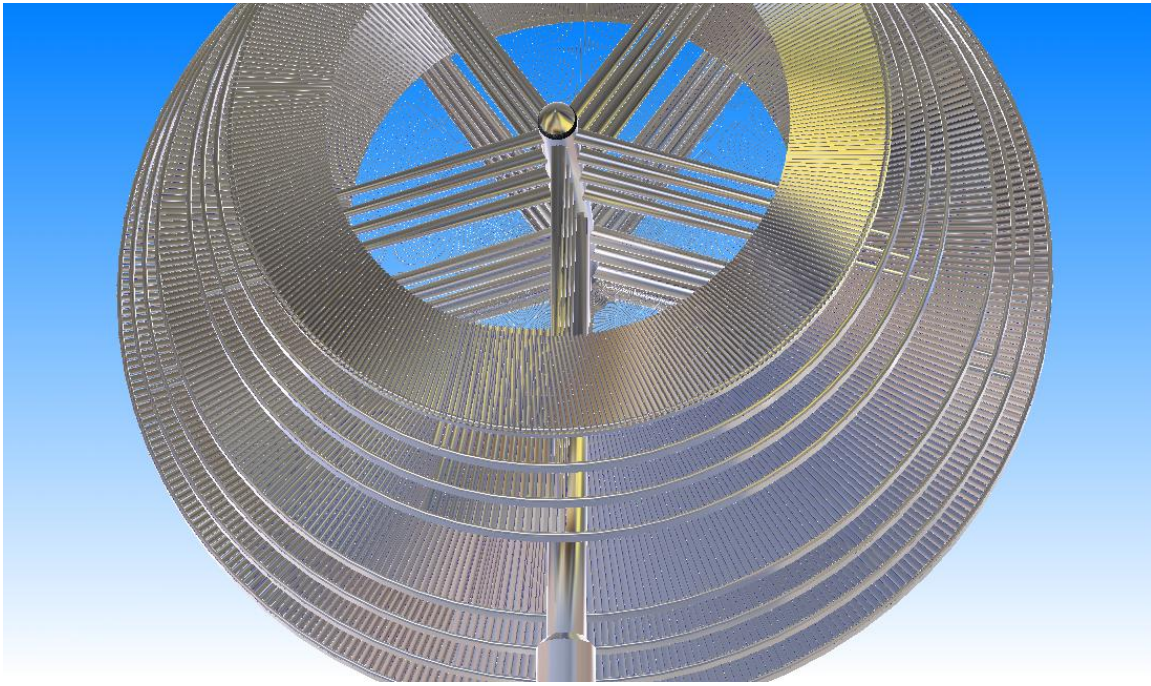

The Global Clean Energy Device was created to improve on the GE models in a wide variety of ways in order to speed up the cleanup of the environment and to make profits that will support growth of the project into many mainstream clean power utilities worldwide.

Why is Global so much better?

11 years of innovation, concepts, testing, planning, prototyping and engineering have resulted in a significant improvement over conventional wind generation devices.

3. OVERALL CONCEPT

The best parts of today's 3 bladed windmills are the tips of the blades. The tips of the blades travel at the highest speed while turning, the tips pass through the greatest volume of air, the tips have the finest aerodynamic shape of the propeller, the tips are the farthest surface from the center of the hub for the highest leverage and the tips carry the highest inertia. The problem with the tips of today's windmills is that out of the 100 tons of windmill swinging 150 foot blades, less than 10% of today's windmills are tips. The current Global Clean Energy Device multiplies the tip surface area by thousands of times.

By placing thousands of aerodynamic tips at the highest distance from the center of rotation the Global Clean Energy Device converts wind energy to large numbers of revolutions per minute of high torque leverage, in other words, POWER.

4. COMPARISON

Wind is variable on Earth from 1mph to 250mph. Why design a propeller windmill, like GE, that operates in only 11mph to 17mph wind? The Global Clean Energy Device is the only wind energy device designed to benefit from the entire range of Earth's wind speeds from 1mph to 250mph with no limits to the amount of power that can be made.

Some of the finest inventions in history have been wheels.

The new Global Clean Energy Device is a wheel, not a pole with 3 giant, spinning swords.

Wheels have many advantages over spinning swords.

Spinning swords on a hub are fighting nature. It is natural for spinning swords to build up centripetal force at speed that pulls the swords off the hub and sends them flying a quarter of a mile if the rpm speed is not controlled. Windmill maintenance personnel have admitted what happens to a GE propeller if the blade feathering device fails to rotate the wings out of the wind to control the rotational speed of the hub. They admit that the high strength bolts that hold the blades to the hub stretch out and the treads of the bolts strip and the 150 foot long blade is thrown off the hub as gravity combines with centripetal force at the bottom of the circle to detach the blade. The spinning inertia carries the blade farther around the circle from the downward position to a sideward horizontal angle which launches said 150 foot long, 10 ton, sword shaped, blade a quarter of a mile before impaling itself into the ground or any thing else. Fighting against nature is not sustainable.

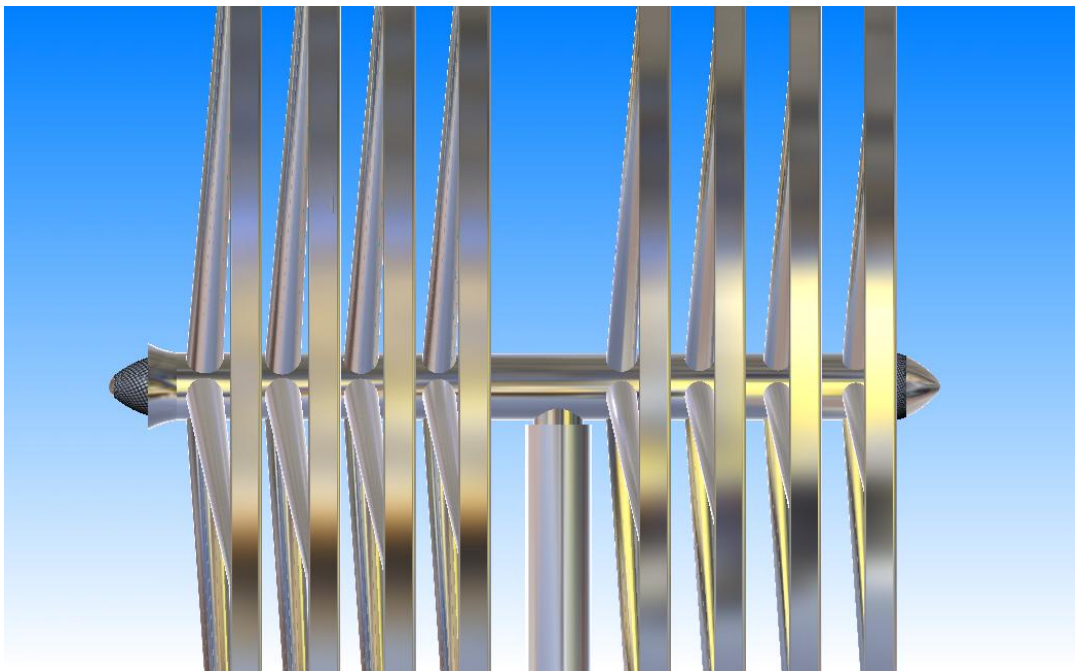

The Global Clean Energy Device works with nature. By using a wheel design with a solid ring on the outside supporting thousands of extremely light weight, aerodynamic blades on the inside, nature works with us by providing gyroscopic stability. The Global Clean Energy Device is a giant, stable, gyroscope. It employs light weight spokes and cables that support the wings and rings in a radial pattern that makes the system more stable at speed utilizing gyroscopic stabilization like the front wheel of a motorcycle at speed. With the cables supporting the ring at hundreds of points around the circumference and the cables threaded directly through the wings, the new system is designed to become tighter and more stable the faster the wind speed.

5. VARIETY OF WIND SPEED

The wings of the Global Clean Energy Device are custom designed for ALL of the wind speeds the Earth has to offer from 1mph to 250mph. GE windmills do not even start moving until 11mph is reached. In less than 1mph, the Global Clean Energy Device is making power. For the first time in history, a wind energy system utilizes 3 separate forms of lift in one seamless system.

The first form of lift is COMPRESSION lift.

The second form of lift is ANGLE OF ATTACK lift.

The third form of lift is VACUUM lift.

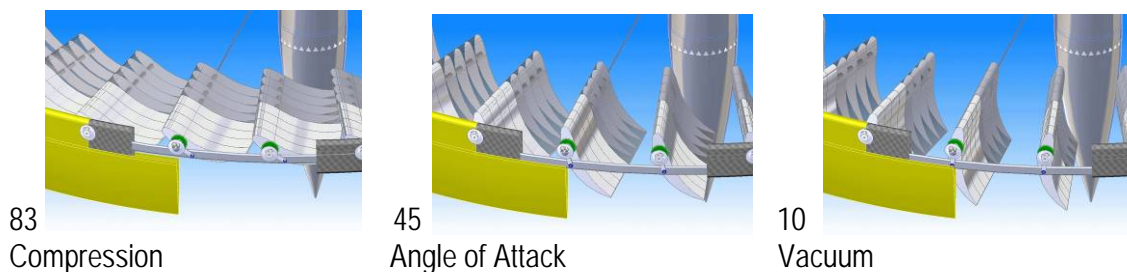

The Global Clean Energy Device has thousands of wings that have variable pitch from 83 degrees closed to 2 degrees open.

COMPRESSION lift is achieved in the 83 degree closed position to the 60 degree position.

ANGLE OF ATTACK lift is achieved in the 60 degree to the 10 degree position.

VACUUM lift is achieved in the 10 degree to 2 degree open position.

(There is a significant amount of overlap in the types of lift in variable wind conditions)

COMPRESSION

The 83 degree closed position presents a very large, circular, surface area of wings, flattened out, tip to tail with a very narrow gap in between each wing. Slow moving air compresses against the flat surface and squirts out of the narrow gap, forming hundreds of spiral air jets to accelerate the ring into revolutions per minute and overcome inertia. This compression lift is a great way to amplify the power of very slow moving wind to provide massive jet thrust and leverage in seemingly powerless wind. Today's GE propellers are over a hundred feet apart at the tips, so there is no way for them to close and take advantage of compression lift.

ANGLE OF ATTACK

The 60 degree, partially open position of the wings provides the second, powerful form of lift. When the wind is deflected from its speed and direction by a wing at an angle of attack, the wing is accelerated perpendicularly to the wind direction which causes revolutions per minute of the wing ring. The variable force of differing wind speeds automatically opens the wings to the appropriate angle of attack to provide the ring with the maximum power with minimum drag.

VACUUM

The 2 degree wide open wing position automatically lowers the rpm at high wind speed while providing more torque and power for high electrical generation in the highest wind speeds on the planet. At 2 degrees the wing is making a very weak spiral through the wind at very low rpm while cranking out pure lift for high power output. By automatically lowering the rpm while increasing the torque at high wind speeds, the tips of the wings at the edges of the rings never approach the speed of sound. This speed and torque optimization is automatic and does not require the use of wind speed sensors, wind direction sensors, computers, stepper motors, gears or switches that might cause the high maintenance of today's 3 bladed propeller systems.

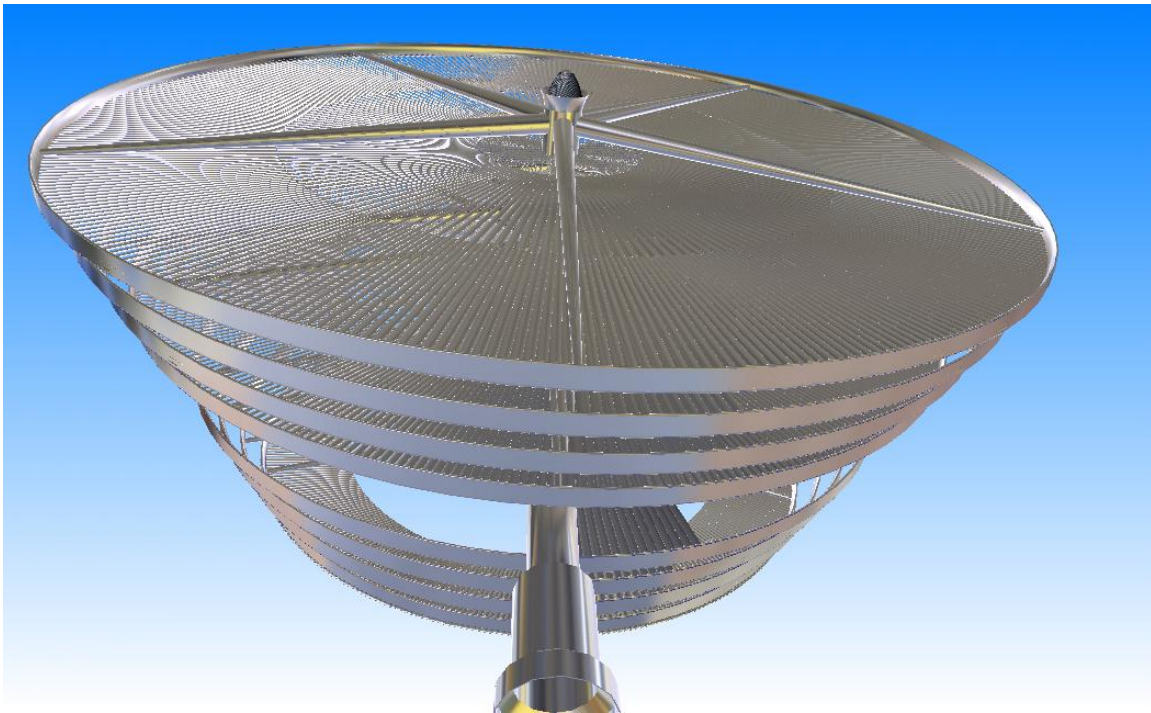

6. PERMANANCE

The Global Clean Energy concept is to use components that you build and forget for hundreds of years. Generally, electronics do not last for hundreds of years, but well designed mechanical systems with no high tech brains will last for hundreds of years. The variable angle of attack blade system for the windmills has been simplified to a handful of unbreakable parts controlling the angle of attack automatically based on wind speed and aerodynamic pressure without any supervision by human beings or computers. When you look at the automobiles of 100 years ago, the electrical systems need to be replaced in order to restore their function. When you look at the springs in the old car's suspension systems, those parts are providing the same function within a tolerance of a

few percentage points over 100 years later. The angle of attack control system consists of an airfoil that is mounted on a pivot that is just in front of the center of aerodynamic lift. This pivot offset allows variable air speeds to automatically adjust the angle of attack to the proper pitch without supervision - forever. By placing the offset point relatively close to the center of aerodynamic lift; spring pressures of only a few pounds are required to automatically adjust to variable wind speeds. In the worst case scenario, a failure of one, or even a hundred, blade springs would not present a catastrophic failure risk because our windmills can have over 1200 blades. Even if ALL of the springs fail, we are still looking at a very efficient automatic angle of attack control system based on aerodynamic pressure alone. The springs are just there to fully close the wings down to catch the maximum air at less than 1 MPH.

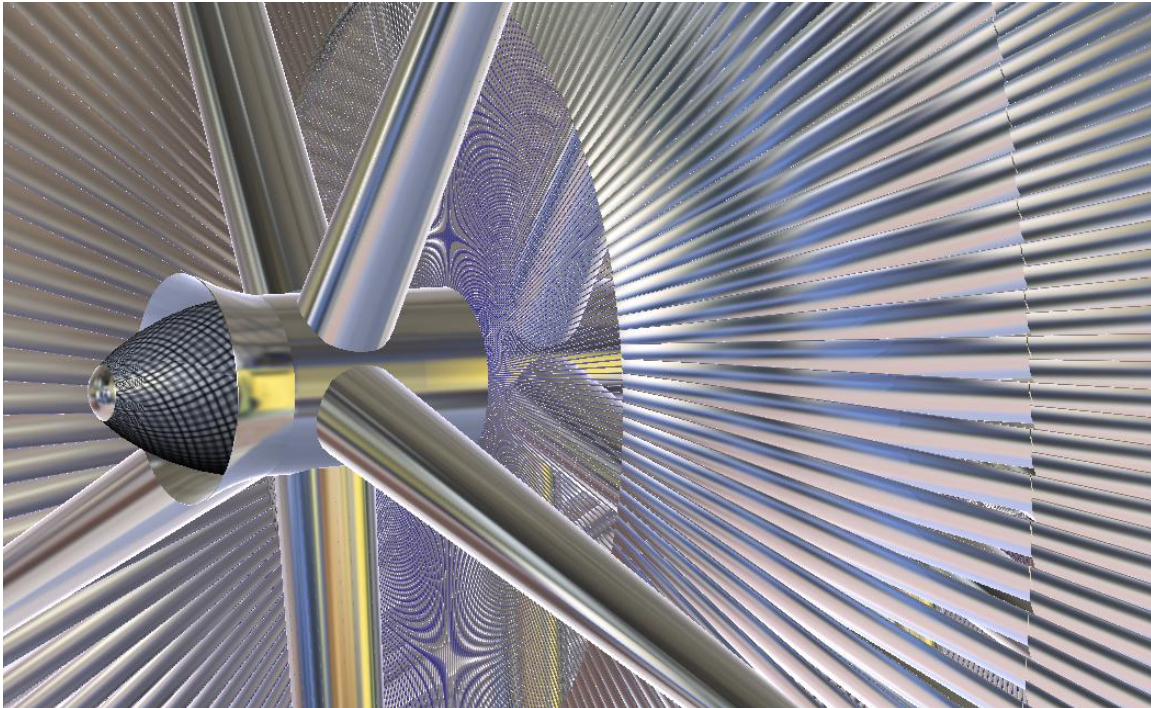

7. ELECTRIC ENERGY GENERATION

Today's 3-bladed windmills utilize a generator system defined back in the 1940's. In the 1940's the first gigantic generators were designed to pull off the power generated by diesel motors at 2000 rpm. These generators have 6 permanent magnet poles that spin at 2000 rpm to make enough magnetic pole changes to reach 60Hz or 60 pole changes per second. It is insane to keep this system designed for diesel engines at 2000 rpm when a windmill spins at between 20 and 200 rpm, but that is exactly what has occurred with the GE products and all other 3 bladed propellers. In fact, the way that GE has mismatched the wind propeller to the diesel type generator is so inefficient as to be criminal. One of the worst designs in GE systems (but not the largest worst) is the transmission. In order to convert the slow rpm of the propeller to the high rpm of the diesel type generator, a truly massive, 5 ton, \$300,000.00 plus, reverse gear ratio, transmission is employed by GE. Using this reverse gear ratio transmission is like jacking up the back of a car and spinning the wheels in order to spin the engine at high speed. At a trade show in the Los Angeles Convention Center a propeller windmill transmission manufacturer proudly proclaimed that their latest transmission has an improved mechanical loss rate of 76% down to just 51% lost energy

going through the transmission from 100 rpm to 2000 rpm. Even at 51%, a loss of over half the power just to accommodate the rpm required by the 1940's type generator is criminal. Then to make matters even worse, the GE system turns out electricity at 660 volts. 660 volts does not match anything useful without a transformer that also wastes energy. High tension power lines are at 85,000 volts or 137,000 volts or at 550,000 volts or at 756,000 volts typically. Why does GE make electricity at 660 volts when the high tension power lines run at high thousands of volts? The 660 volts have to run through a transformer to go from 660 to hundreds of thousands of volts. Transformers have inherent loss during the transformation process. It is almost a criminal loss to make power at the wrong voltage for use. The Global Clean Energy Device solves all of these problems.

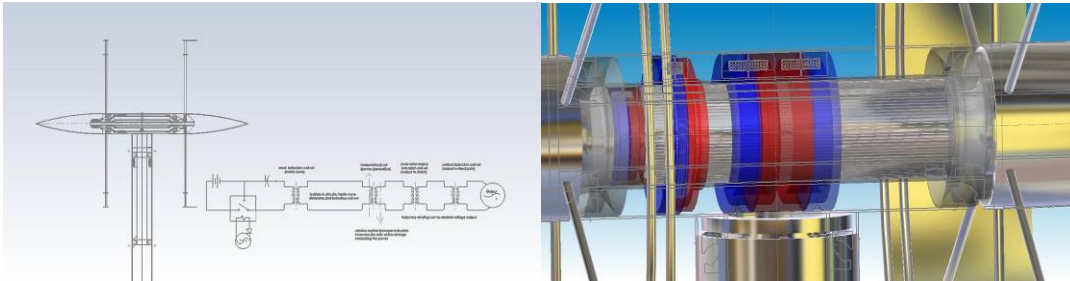

8. WIND POWER APPROPRIATE ALTERNATOR/GENERATOR

The Global Clean Energy Device is custom designed for all of the wind speeds on the planet Earth from 1 mph to 250 mph. Instead of the GE 6 permanent magnetic poles, the Global device has 6000 infinitely variable electro-magnetic poles. This allows the new device to make alternating current of 60Hz at extremely low wind speeds. In wind speeds of as little as 1/5th of 1 mph, the new device can make direct current power. In wind speeds from 1 or 2 mph the new device can make alternating current at 60Hz. The Global Clean Energy Device has an alternator not a generator. Alternators have infinitely variable amounts of magnetic energy that can be custom programmed to control the exact amount of electric energy is drawn off at each wind speed. This allows the alternator to control the rotational speed of the windmill by drawing small amounts of power at low speeds, promoting momentum and very, very, large amounts of power at high speeds while slowing down the rpm in high winds which is a benefit.

The Global Clean Energy Device is custom designed to create voltage that matches the corresponding high tension power line voltage and frequency. For the first time in history, the output requires no wasteful transformer to supply the proper electric power to the grid.

The Global Clean Energy Device requires no wasteful mechanical transmission. By custom designing this wind device for the wind speeds of the planet Earth, instead of for an arbitrary rpm set by the historical use of diesel engines, there is no need for the heavy, expensive and wasteful mechanical transmission found in today's GE propeller machines.

9. BUSINESS DESCRIPTION

The worldwide need for clean, renewable, electric power is growing at an astronomical rate. Global offers a significantly more efficient wind power generation system than conventional 3 blade wind systems at half the cost of manufacturing.

TWICE THE POWER AT HALF THE COST. No propeller company can compete with that.

Today's electric power is most prevalently derived from dirty, polluting or radioactive sources. Dirty electric power plants pump more than 11 million tons of pollutants into our air every year.

According to numerous scientific sources, clean renewable energy reverses global warming.

Global has potential profits of billions or trillions while improving the environment.

10. MANAGEMENT

Brad Sorensen – Founder, Inventor, CEO, is an industrial designer and inventor who has created over 800 vehicles, products, packages and trademarks for over 400 companies resulting in over \$300,000,000,000.00 in client sales worldwide. The designs include the 1986–1992 Mazda RX7 sports car and Volvo 850 sedan, station wagon and coupe, Freightliner semi-trucks, Lockheed jet aircraft, U.S. Navy aircraft carriers, race cars, power boats, sail boats and other vehicles. He has extensive experience in the fields of aerodynamics, molding, materials forming, die casting, welding, stamping, extrusion, heat sealing, laminating, coating, finishing and prototype model building. Additionally, he writes 95% of his own patents. He graduated from the Art Center College of Design highest in his class (3.65 GPA) with a Bachelor of Science Degree in Transportation Design.

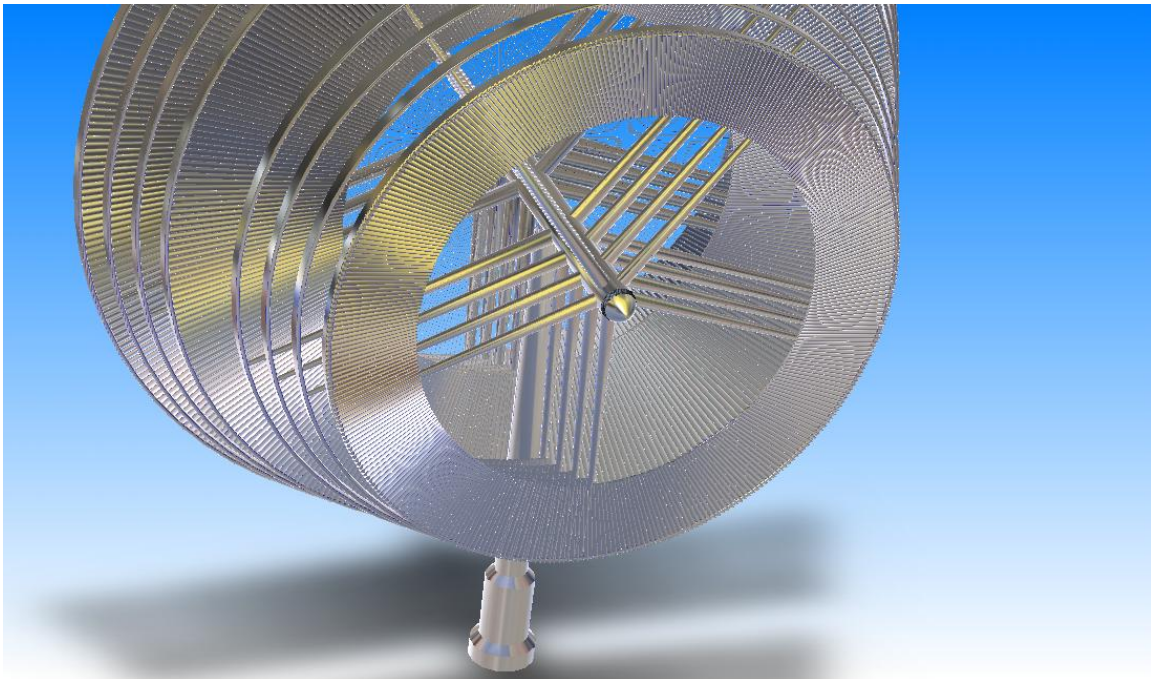

11. PERSONNEL

Since the technology is designed to be installed in months and have an automatic return of power and income with each passing wind, with very little maintenance, very few full time employees will be necessary. Most of the construction, installation and maintenance of the systems will be outsourced to local contractors as needed to stimulate the creation of jobs in the local area. Investors in this technology will have an unprecedented ability to place their own key officers, accountants, supervisors, managers and employees in administrative and monitoring positions.

12. TECHNOLOGY/PROPRIETARY RIGHTS

The Global intellectual property is covered by 1999 and 2006 Utility Patents. It is also covered by a pair of licensed utility patents that were issued in 2003. At least 7 more international patents covering specific details of the latest designs are scheduled to be added to provide a 20 year monopoly each. Constant addition of more patents during the monopoly period will extend the patent coverage beyond the original 20 year coverage.

13. PROTOTYPE TESTING

Prototype models of the product have been built in two sizes for testing in wind tunnels at the University of Southern California and at Cal Tech. The results of wind tunnel tests can be scaled up to predict the performance of the system at any size within a tolerance of a few percentage points. The Cal Tech wind tunnel tests administered to the ducted blade ring fan system resulted in a ten times improvement over a typical 3 bladed fan system. A system that turns electric energy into wind power can turn wind power back into electrical energy. Our turbines are simple to build. We can build within 3 to 6 months of approvals and funding. The comparative low cost of product construction and the super efficient production of virtually limitless wind power, will set the new, national, green power standard for the world.

14. MARKETS

The wind energy business is in the billions now and into the trillion dollar annual income potential in the near future. Utility companies, countries, groups and individuals worldwide need clean, renewable electric energy. Clean, cheap, renewable, non polluting electric energy is easy to sell. The market is almost limitless. The applications of this energy are as wide as the imagination. We could start with the aluminum industry. Some aluminum plants have been known to require over 40% of a hydro power dam output to satisfy the need for raw electric power.

15. DISTRIBUTION CHANNELS

The goal is to provide power to world market companies, groups and individuals with at least 20% less cost than today's electric rates while maintaining significant profit margins. The customer base is wider than wind power today. The new technology can promise more energy with fewer turbines and exceptionally more energy with equal or more turbines, than current wind generators are producing. Our technology works in significantly lower wind speeds and significantly higher wind speeds, so the system has more versatility regarding where it can be built. Retrofitting or replacing existing wind farms or windmills is also a great strength of the distribution plan,

considering we can use existing turbine poles to improve current propeller performance up to jet turbine performance.

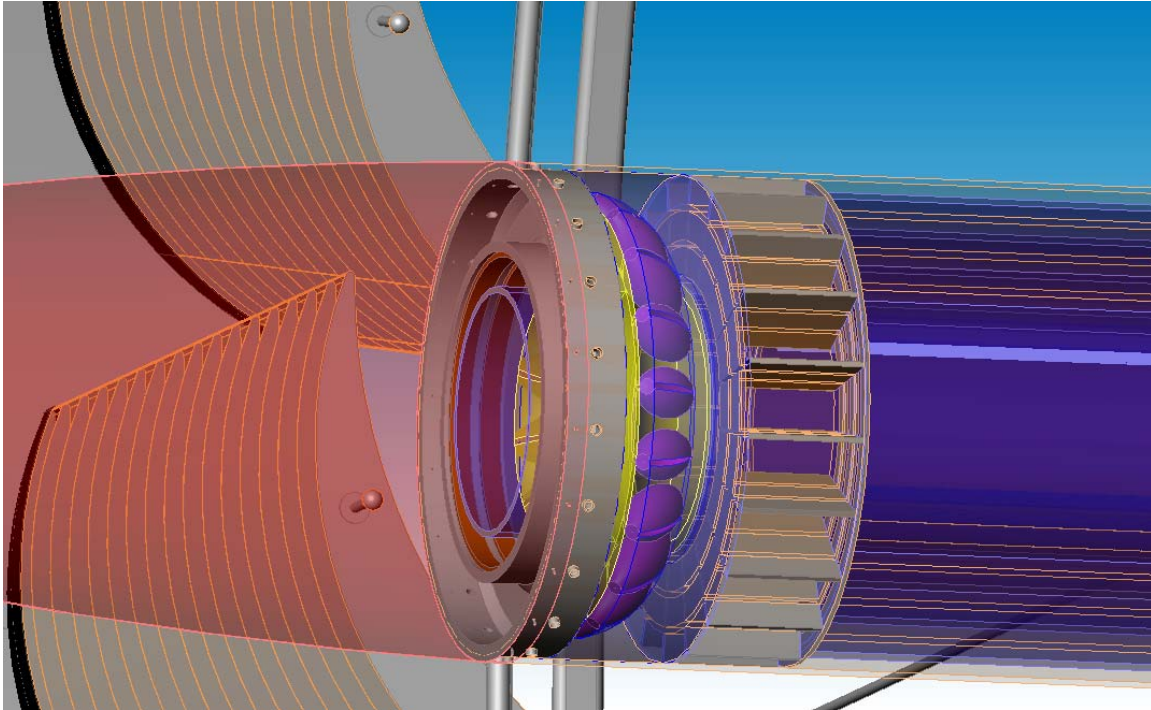

16. COMPETITION

The Global electric energy generator is a jet ducted turbine not a dated propeller. Global replaces 1944 technology propellers. Global places huge, variable pitch, aerodynamic surface area at the largest diameter of a ducted fan turbine for tremendous power. The Global electrical alternator/generator has a significantly wider effective wind speed range allowing custom power production for each application. Global has a lower cost of construction and maintenance than current 3 bladed propeller wind power generators. Global is powered by sun and wind driven perpetual energy. Global displaces and therefore reduces emissions of CO₂ and NO_x from petroleum and coal fired power plants. States now mandate that between 7 and 20 percent of all power be generated from renewable sources, however current wind turbines are not cost or time efficient, nor are they service friendly.

17. INDEPENDENT ENGINEERING REVIEW



John C. Bell
Principal Engineer
C-17 Flight Controls
USAF Airlift & Tanker Program

The Boeing Company
3855 Lakewood Blvd MC D041-0080
Long Beach, CA 90846-0001

Telephone 562-593-8330
Cellular 562-234-1417
Fax 562-496-7925
john.c.bell2@boeing.com



The SORENSEN DESIGNED WINDMILL Independent Engineering Analysis Result

The Sorensen Designed Windmill (SDW) is a superior design that produces clean energy. It has out-performed conventional windmills in comparison tests. My name is John Bell, Principle Engineer with The Boeing Company, and I've come to these conclusions after witnessing side-by-side, measured comparisons of the SDW with a conventional-designed windmill.

The design of the SDW is supported by sound analytical concepts. It produces more energy at lower wind speeds and more efficiently (and safely) than do conventional alternatives. Furthermore, the SDW has an easy-to-maintain structure.

In addition to witnessing the side-by-side test and my review of written supporting documentation, I also had all of my technical and directed questions answered. All aspects pertaining to SDW's construction, functionality, maintainability, and safety have been addressed and answered to my satisfaction.

Based on the design concept, the feasibility study, and the demonstration of the prototype's ability to generate electricity, I conclude that the Sorensen Designed Windmill is a safe and efficient means of creating clean energy from wind, superior to other existing designs. It is well-thought out and its design is both viable and maintainable. Based on the comparison test and my review of supporting documentation, I conclude that the SDW is better by design.

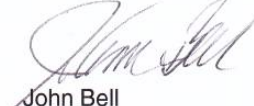
 10/24/07
John Bell
Principle Engineer
The Boeing Company

18. RETURN ON INVESTMENT

Global LLC will make money in 6 main ways.

1. Sales of Global electric power to the grid.
2. Sales or lease of Global wind power generator systems.
3. Brokering renewable energy credits to satisfy mandated renewable energy quotas.
4. Retro-fitting existing propeller poles with Global turbines.
5. Royalty and licensing agreements.
6. Tax incentive programs, depreciation, tax credits, and other government programs

Global wind generator systems are much more efficient and less costly than today's propeller systems; therefore, there are functional and economic justifications for growth.

Clean, renewable energy is in high demand and is projected to grow.

Global can attract the finest executives and employees because of the popular, positive, clean, renewable and profitable aspects of wind energy. We plan to hire the top people from other wind energy systems as the efficiency of our system causes defections.

Nevada alone will provide a substantial Return on Investment.

The World will be a Global.

Sierra Pacific Nevada Power needs to increase their renewable energy to 20% from the current 7% to comply with government mandates. The attached Request for Proposals outlines their needs.

Nevada Power is offering a 20+ year Power Purchase Agreement for On Peak (minimum & maximum) renewable electric power generation. On Peak \$68.60 (minimum) per megawatt hour X 100MW guarantee = \$6,860.00 per peak hour X 16 hours per day = \$109,760.00 X 365 days per year = \$40,062,400.00 per year X 20 years contract = **\$801,248,000.00** for 20 years with renewals of contract possible. On Peak \$77.07 (maximum) per megawatt hour X 100MW guarantee = \$7,707.00 per peak hour X 16 hours per day = \$123,312.00 X 365 days per year = \$45,008,880.00 per year X 20 years contract = **\$900,177,760.00** for 20 years with renewals of contract possible.

Return on investment will come from the Nevada power contract as well as any other contracts that can be generated worldwide.



19. FRANCHISE RETURN ON INVESTMENT

Global Clean Energy is forming franchises to service areas and populations.

1. Franchises will provide a return on investment by selling power in franchise areas.
2. Franchises will provide additional income by selling power to governments.
3. Franchises will generate renewable energy credits for cash or brokering to others.
4. Franchises will provide power to electricity hungry industries like aluminum production.
5. Franchises will generate water as well as power in outlying areas.
6. Franchises will provide instant electricity and water to mobile military installations
7. Franchises will provide clean pumping services for water and oil.

The large windmills make income of approximately double their cost in the first year, thereafter, windmills make nearly 100% profit because there is no fuel cost.

A windmill can be built in 3 to 6 months. A windmill can pay for itself in 6 to 9 months, with nearly pure profit after that.

Some examples of franchise areas are as follows:

Chicago \$800M, 80windmills, 2480MWh, \$1,352,680,000.00 per year, ROI 9mo after completion
Manhattan \$2B, 200windmills, 6200MWh, \$5,431,240,000.00 per year, ROI 9mo after completion
Dubai \$100M, 10windmills, 310MWh, \$272,560,000.00 per year, ROI 9mo after completion

The first windmills will be portable windmills in a box which can be set up in the parking lots of aluminum plants or water and power companies for instant clean energy.

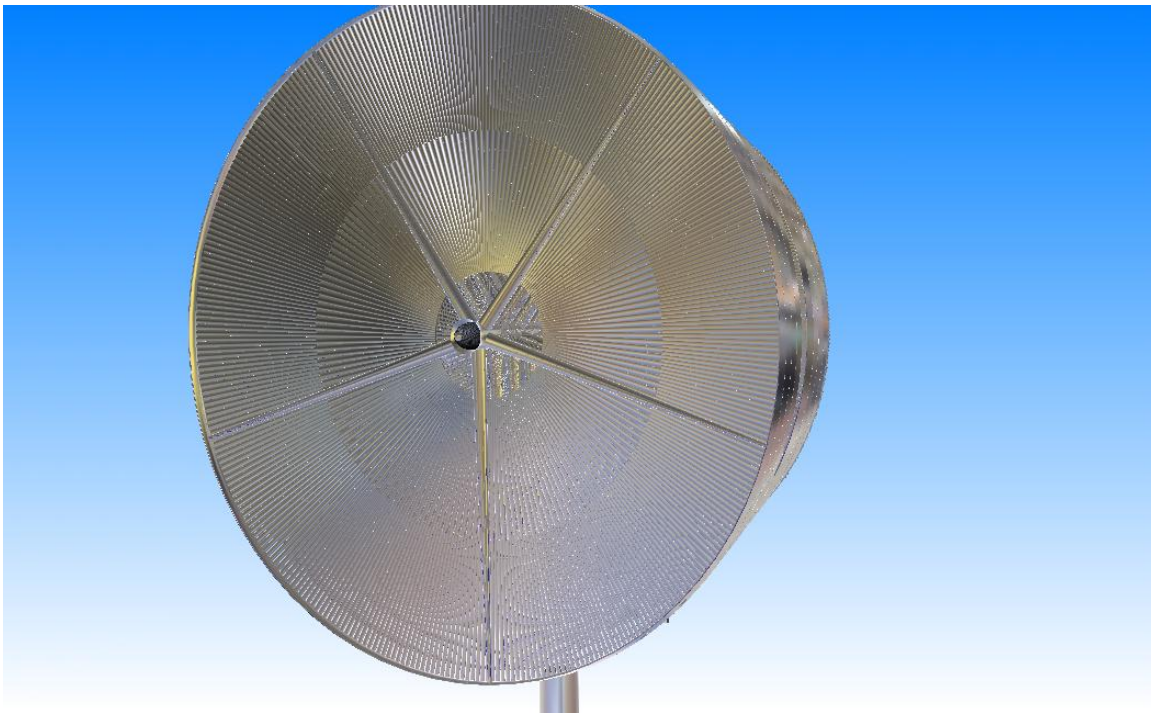

20. NATIVE AMERICAN COOPERATIVE RETURN ON INVESTMENT

Specific Focus

Global Clean Energy plans to utilize the advantages afforded to American Indian tribes to benefit the tribes and to grow our company fast.

American Indian tribes have distinct advantages in wind energy.

1. American Indian tribes pay no taxes. They are a sovereign nation within America.
2. American Indian tribes have a treaty with the U.S. Government stating that the electric utilities in first position and the government in second position must buy all power made on the reservation at peak rates no matter how much power is generated.

These advantages make American Indian reservations very desirable. We have contacted at least three American Indian tribes (Paiute, Shoshone and Cherokee) with great response. The tribes are looking for income, jobs and growth. Global clean energy provides all of those advantages and more to the American Indians as well as providing a plentiful, clean, renewable, electric, energy source to the public.

The Paiute Indian Tribe north of Las Vegas, Nevada has a coal fired power plant on their reservation.

Global Clean energy would build as many windmills as possible with the amount of investment available at a rate of twice the power at half the cost of General Electric wind power systems. The Paiute Indian Reservation land is perfect for wind power. It has valleys that focus wind power as well as plateaus that provide an updraft and concentration of wind speeds at ground level. There is very little vegetation or trees that would cause aerodynamic drag or thickening of the boundary layer on the Earth's surface. Therefore, the wind is fast, focused and laminar which is perfect for the production of significant amounts of wind power. Many high tension power lines cross the Paiute Indian Reservation. There are many power sub stations for connecting to the electric grid located on the reservation. The windmills could be placed close to the existing power

lines and substations in order to cut the distance for electrical transmission losses for high efficiency.

The larger the investment, the more windmills we can build, the more power we can make. The State of Nevada has a mandate to produce 7% of its electrical power by clean, renewable sources like wind, solar and hydroelectric. According to Sierra Pacific Nevada Power public records, they are at less than 1% clean power as of today's date. When Global Clean Energy creates power, it will help increase the rate from 1% to 7% and collect valuable energy credits.

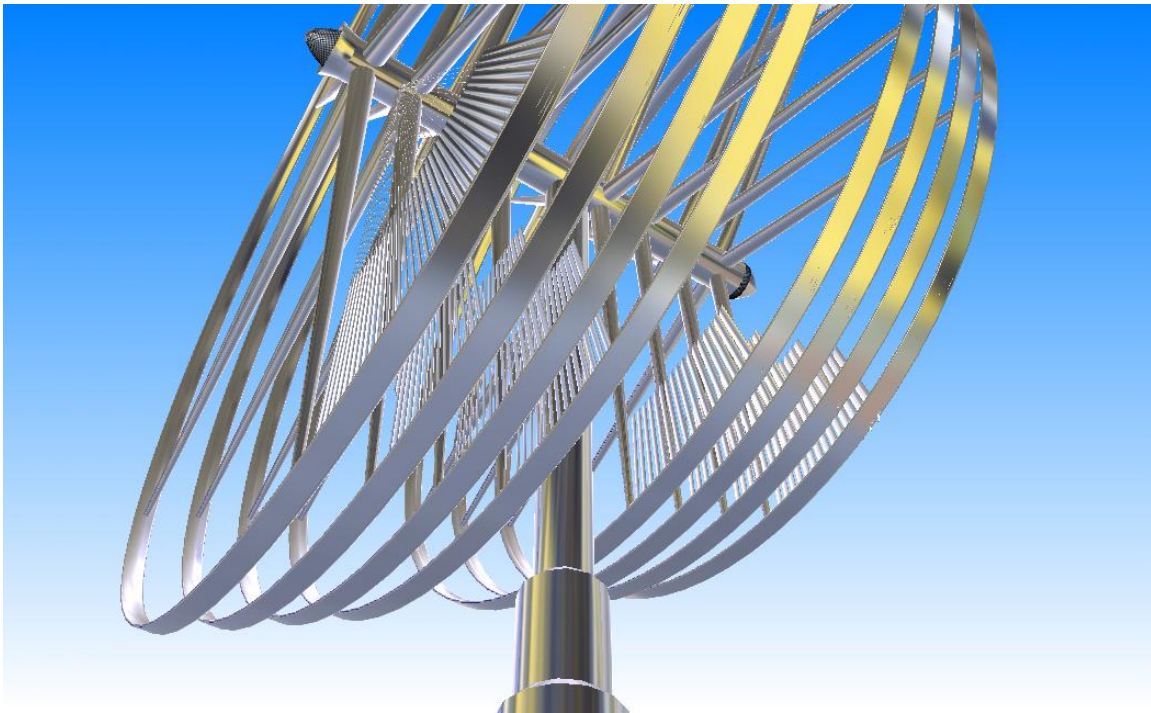

21. USE OF FUNDS CHART

Global Clean Energy Use of Funds

Windmill components	21%
Windmill assembly	16%
Windmill shipping	3%
Windmill testing	2%
Windmill installation	9%
Windmill land acquisition	14%
Windmill security fence	1%
Windmill connection to grid	1%
Windmill power meter	1%
Windmill power monitoring	1%
Windmill power accounting	1%
Windmill income collection	1%
Windmill intellectual property	5%
Windmill construction facilities	5%
Windmill sales personnel	7%
Windmill product development	5%
Windmill public relations	2%
Windmill insurance	2%
Windmill maintenance	1%
Windmill political fund	1%
Windmill legal fund	1%
	100%

22. SUMMARY

The worldwide need for clean, renewable, electric power is growing at an astronomical rate. The Global electric energy generator is a jet ducted turbine not a dated propeller. Global replaces 1944 technology propellers. Global places huge, variable pitch, aerodynamic surface area at the largest diameter of a ducted fan turbine for tremendous power. The Global intellectual property is covered by 1999, 2003 and future Utility Patents provide a 20 year plus monopoly. The Global electrical generator has a significantly wider effective wind speed range allowing placement in 95% of worldwide land areas and 99 % of all water areas. Global has a lower cost of construction and maintenance than current 3 bladed propeller wind power generators. Global is powered by sun and wind driven perpetual energy. Global displaces and therefore reduces emissions of CO2 and NOx from petroleum and coal fired power plants. According to numerous scientific sources, clean renewable energy reverses global warming. Global has potential profits of billions or trillions while improving the environment. Today's electric power is most prevalently derived from dirty, polluting, radioactive sources. Electric power plants pump more than 11 million tons of pollutants into our air every year. Some States now mandate that between 7 and 20 percent of all power be generated from renewable sources, however current wind turbines are not cost or time efficient, nor are they service friendly. Global offers a significantly more efficient wind power generation system than conventional 3 blade wind systems at half the cost of manufacturing. Current 3 blade systems are

only efficient at the 3 blade tips that are spaced far apart, because most of a propeller at the center of rotation. The new system places over ten times as many wing tips at the largest diameter of the rotation of the wind generator to create more torque and electric power at lower wind speeds than currently available. According to the AWEA, current models require an 11-17 mph wind. The utility patented multi wing-tip ducted RPM generator has a ring shaped, spinning and gyroscopic centripetal flywheel. The flywheel rides on excellent bearings to virtually eliminate rotational and thrust friction. The spinning wing-tip ducted flywheel imparts RPM power for generation by using frictionless induction rather than contact brushes that can wear. The use of the innovative aerodynamic design of Global maximizes balanced wind forces from the top of the ring to the bottom of the ring, providing even rotational pressure distribution, making the generator as efficient as possible. Wind-Win's wind generation system was originally covered by a 1999 patent, relating to an ultra-efficient fan system which stops competitive companies from getting a patent similar to this technology. The wind tunnel tests administered to the fan system resulted in a ten times improvement over a typical 3 bladed fan system. A system that turns electric energy into wind power can turn wind power back into electrical energy. The wind energy business is in the billions and into the trillion dollar annual income potential in the near future. Our turbines are simple to build. We can build within 3 to 6 months of approvals and funding. The comparative low cost of Global construction and the super efficient production of virtually limitless wind power, will enable our client power companies to set the new, national, green power standard for the world. The larger the diameter is, the greater the torque is on a geometric scale, thus producing more energy. The Global customer base is wider. Global can promise more energy with fewer turbines and exceptionally more energy with equal or more turbines, than current wind generators are producing. Global has more versatility regarding where it can be built.



23. GOAL

The intention is to reduce air pollution, reduce global warming and save the planet while making a fortune.

24. CONTACT

Brad Sorensen, 310-802-8082, sorensen.design@gte.net

25. ENERGY PRODUCED AT EACH WIND SPEED CHART

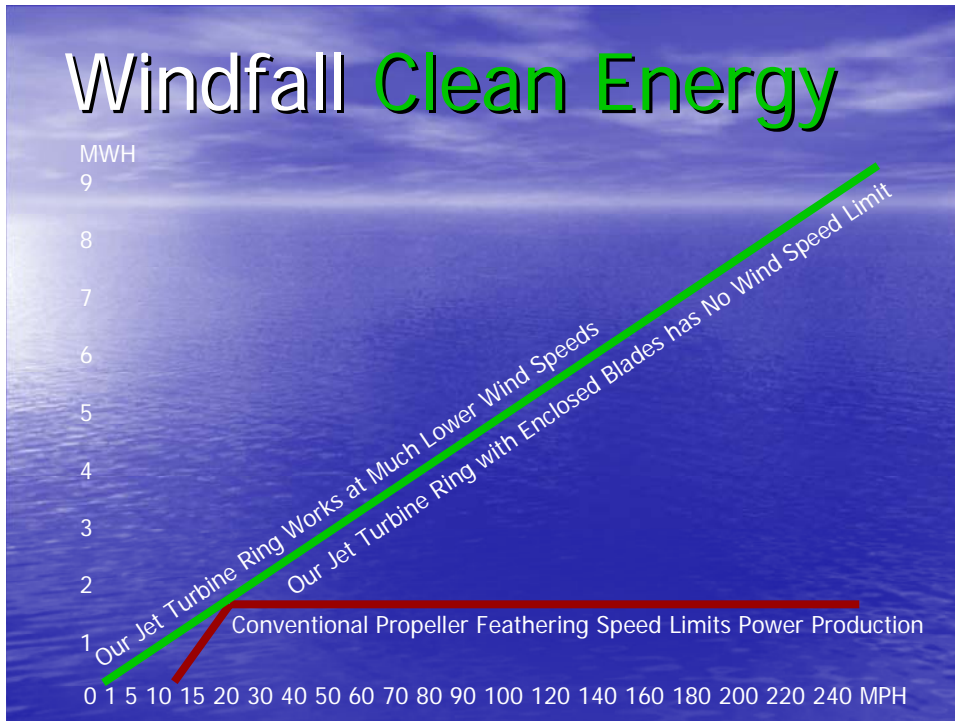

26. PROPELLER COMPARISON CHART

Windfall Clean Energy

100 meter G.E. or Vestas propeller	100 meter Windfall Clean Energy
100 tons	10 tons
3 blades	3000 blades
6,362 square meter wing tips	887,364 square meter wing tips
1 MWh	10 MWh (theoretically could be 147 MWh)
Centripetally unstable at high speeds	Gyroscopically stable at high speeds
\$300K 51% efficient RPM transmission	No transmission loss
Effective wind speeds 11-17 mph	Effective wind speeds 1-250 mph
10% of blades at high leverage distance	100% of blades at high leverage distance
6 pole generator	6000 pole alternator
Alternating current at 3000 generator rpm	Alternating current at 100 alternator rpm
Output 660 volts at 60 Hz	Output 13700 volts at 60Hz

For more information, contact Brad Sorensen at 310-802-8082 sorensen.design@gte.net

27. COAL COST COMPARISON CHART

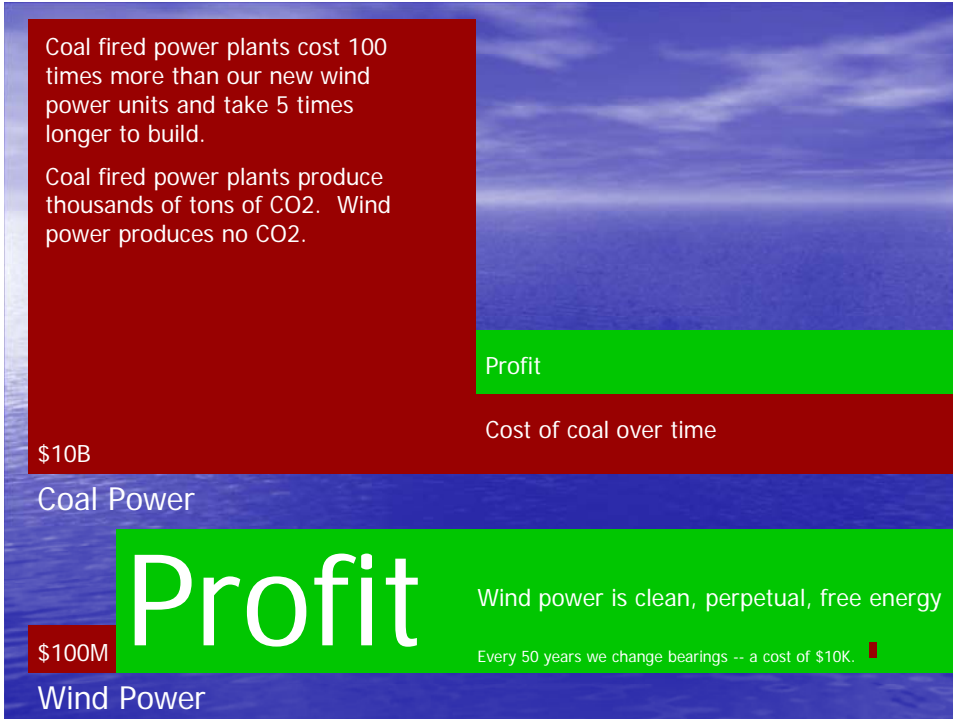

28. PRODUCT COMPARISON CHART

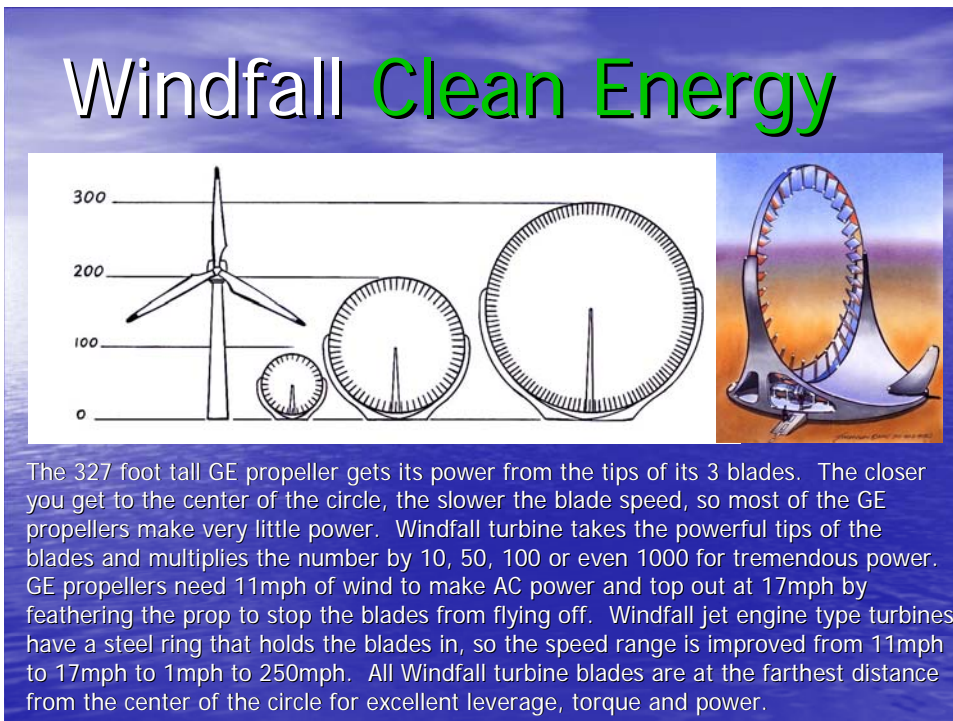

29. SAMPLE BUSINESS STRUCTURES

There seems to be an infinite number of business structures that are possible related to this project.

Each investor, business man, entrepreneur, utility, government, corporation, banker, venture capitalist, energy broker, industrialist, individual or individuals have their own ideas regarding the business structure that suits them perfectly.

Many alternative business structures have been suggested, here are a few.

1. Creation of an independent clean energy utility where an investor buys 49% of the company for the capital necessary to get to a return on investment. The investor gets his funds paid back first from generated power and energy credits, once paid back, then the split reverts back to 49% investor and 51% Global Clean Energy. If any equity percentage goes to brokers, it comes out of the investor's 49%.
2. Joint venture with an existing power utility company where the power company finances the creation of the windmills, made by Global Clean Energy, necessary to make a certain amount of power. Because the existing power utility has valuable customer base, does supportive advertising and has existing electric grid connection, the split is Utility 80% - Global 20%.
3. Creation of a high production factory to produce small windmills on a high production basis. Investor would buy a factory, equipment and labor to produce thousands or millions of products. The investor gets his funds paid back first from product leases, generated power and energy credits then the split reverts back to 49% investor and 51% Global Clean Energy. If any equity percentage goes to brokers, it comes out of the investor's 49%.
4. Wind farms will be formed with an investor who buys 49% of the wind farm company for the capital necessary to get to a return on investment. The investor gets his funds paid back first from generated power and energy credits, once paid back, then the split reverts back to 49% investor and 51% Global Clean Energy. If any equity percentage goes to brokers, it comes out of the investor's 49%.
5. Licensing the technology is negotiable.
6. Franchising the technology is negotiable.
7. Sales of exclusive sales territories are negotiable.
8. Taking individual companies' stock public is negotiable.
9. Direct orders of products are negotiable.
10. Purchase of clean energy credits is negotiable.
11. Suggest your own business structure.

30. CORPORATE RESOLUTION

Global Clean Energy hereby resolves to appoint Brad Sorensen as the authorized signatory for the company.

Brad Sorensen is the inventor of the technology, the founder of the company and the 100% owner of Global Clean Energy.

Brad Sorensen will also negotiate for the company in all matters.